

Donahaye, E.J., Navarro, S., Bell, C., Jayas, D., Noyes, R., Phillips, T.W. [Eds.] (2007) Proc. Int. Conf. Controlled Atmosphere and Fumigation in Stored Products, Gold-Coast Australia. 8-13th August 2004. FTIC Ltd. Publishing, Israel. p. 47-52

## **QUICK STORED PRODUCTS DISINFESTATION BEFORE PROCESSING: ONE OR TWO DAY PHOSPHINE FUMIGATION.**

P. DUCOM, C. ROUSSEL AND V. STEFANINI

*Laboratoire National des Denrees Stockees, Chemin d'Artigues, 33150, CENON-BORDEAUX, France, Corresponding author: patrick.ducom@agriculture.gouv.fr*

### **ABSTRACT**

Quick disinfestation of stored products infested by insects is usually carried out with methyl bromide fumigation. In less than 24 hours, all insects stages are killed. With the phase-out of MeBr, this technique will disappear. Nevertheless, in many situations, there is no necessity to do a total disinfestation, for example when the product is to be directly processed. Only flying and crawling insects which can disperse have to be killed. Eggs and pupae will be killed during the processing. In these conditions, phosphine may be used at a very low dosage and for a short time. Trials have been carried out with seven adults of different species (*Cryptolestes ferrugineus*, *Oryzaephilus surinamensis*, *Sitophilus granarius*, *Sitophilus oryzae*, *Sitophilus zeamais*, *Tribolium confusum* and *Tribolium castaneum*), at two concentrations, 30 and 60 ppm, during six exposure times of 12, 24, 36, 48, 60 and 75 hours and for four temperatures 10, 15, 20 and 25°C. Results show that at 10°C, the differences between species are important, the most sensitive being *O. surinamensis*, the only one killed at 10°C with 30 ppm in less than three days. At 25°C, almost all species are killed in 24h with 30 or 60 ppm, except *S. zeamais* and *T. castaneum*. At the dosages and times tested, the time to kill adults depends both dosages and temperature. In conclusion, when a product is to be processed, a quick phosphine fumigation allows all mobile insect stages able to infest the plant to be killed. In addition, desorption requires only a few hours, allowing a quick and safe handling.

### **INTRODUCTION**

When a product is to be quickly disinfested, usually methyl bromide (MeBr) is used for a 24h fumigation. However, this fumigation kills all stages of insects. Methyl bromide is to be phased out, and the only currently available fumigant is phosphine.

To kill all stages as MeBr does, phosphine requires several days and, as a result, it is not suitable for this purpose. However, there are some cases where complete disinfestation is not necessary. When a product is to be processed immediately after entering the plant and if it is recognised as being infested by insects, it is not necessary to kill the stages contained within the product. Only the flying and crawling insects which can spread out into the processing plant need to be killed since the processing procedure will kill the insects trapped within the product. For example, processing of cocoa beans begins by cleaning, sifting, suction and sorting. Then, to remove the skins, the beans are heated on a fluidised bed at 80 – 100°C during 15 minutes. After this they are pulverized, put in boiled caustic soda, etc.! . Other situations of infestation in products to be processed are solved in a similar way for example coleoptera in sunflower or canola for oil processing.

The aim of this preliminary work was to evaluate, the efficacy of phosphine for different insect species, under different fumigation conditions.

We have assumed that moths are very easy to kill, and therefore the experiments were carried out on adult coleoptera only.

## MATERIAL AND METHODS

### Insects

The following seven insect species were tested as young adults:

*Cryptolestes ferrugineus*, the rust-red grain beetle

*Oryzaephilus surinamensis*, the saw-toothed grain beetle

*Sitophilus granarius*, the grain weevil

*Sitophilus oryzae*, the rice weevil

*Sitophilus zeamais*, the maize weevil

*Tribolium confusum*, the confused flour beetle

*Tribolium castaneum*, the rust-red flour beetle

The insects were reared at 27°C and 70% RH on media adapted to each species: whole grains for the *Sitophilus* species, flour meal for the *Tribolium* species, whole flour for the other ones.

The insects were put in batches of 100 to 300 in small aerated containers (film boxes) with a small amount of suitable food medium. The insects were then placed at the fumigation temperature for at least 3 days before the treatment. Insect control batches were placed at the same room temperature.

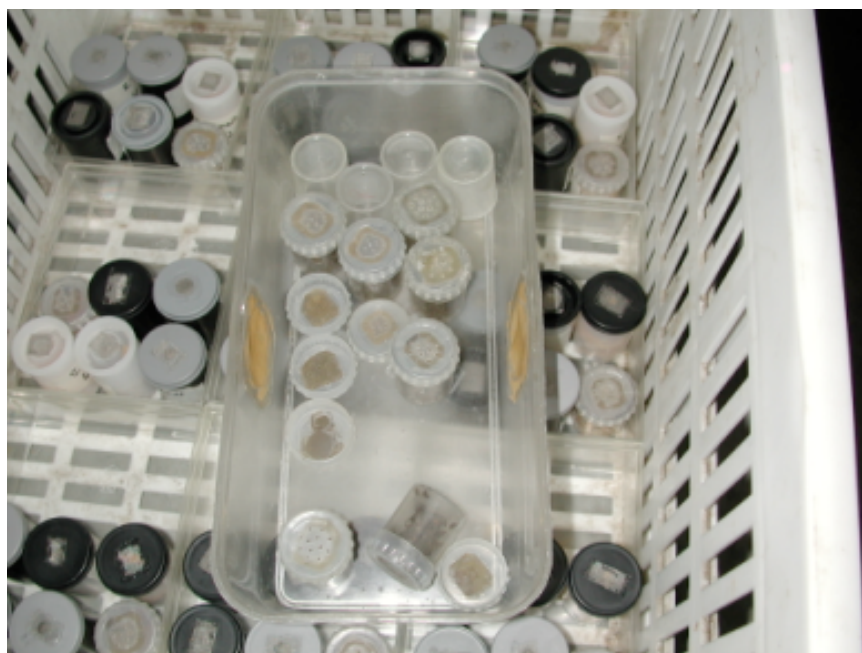

Figure 1. Insects in their film boxes or containers

### **Insect observation**

After the fumigations the insects were observed twice, 7 and 14 days after the end of fumigation. As this type of fumigation has to meet the requirement that no live insect be found during inspection at the marketing stage, those insects found in a moribund state were counted as alive should they be able to move even only a leg, or antennas, etc. Since the results of the 7 and 14 days observations were very similar, the seven day results were used and mortality counts were subjected to probit analysis (SAS).

### **The Fumigations**

Two low dosages were used, 30 and 60 ppm. The temperatures were those usually found in Europe at different seasons: 10, 15, 20 and 25°C.

Exposure times were 12, 24, 36, 48, 60 and 72 hours. Two replicates were carried out.

The fumigations are carried out in 11 litres stainless steel vaults (fumigation chambers) placed in an air-conditioned room. The small boxes containing the insects were introduced into the vaults immediately before the fumigation.

Six vaults were linked together in parallel by tubes connected to a 1 m<sup>3</sup> fumigation chamber and a recirculation fan that maintained an even gas concentration in all parts of the system. The generator consisted of pellets of magnesium phosphide Mg<sub>3</sub>P<sub>2</sub>

from Detia Degesch which were placed in the 1 m<sup>3</sup> chamber. This chamber provided the gas supply to avoid quick changes in case of leaks



Figure 2. View of fumigation chambers from above

### **Gas measurements**

Concentrations were continuously controlled by an electrochemical cell placed inside the chamber and connected to a computer. Once a day, the value was checked by another electrochemical meter (Portasens II from ATI), which was regularly checked with a reference gas (Messer, 1031 ppm).

If necessary, i.e. if the phosphine concentration decreased below ~20%, it was adjusted in the chamber by adding the calculated amount of solid fumigant generator.

Every 12 hours, one vault was disconnected and the insects put in a room at 25°C and 70% RH.

### **RESULTS**

One day fumigations were carried out at 30 ppm with a temperature > 25° and at 60 ppm with a temperature > 20°

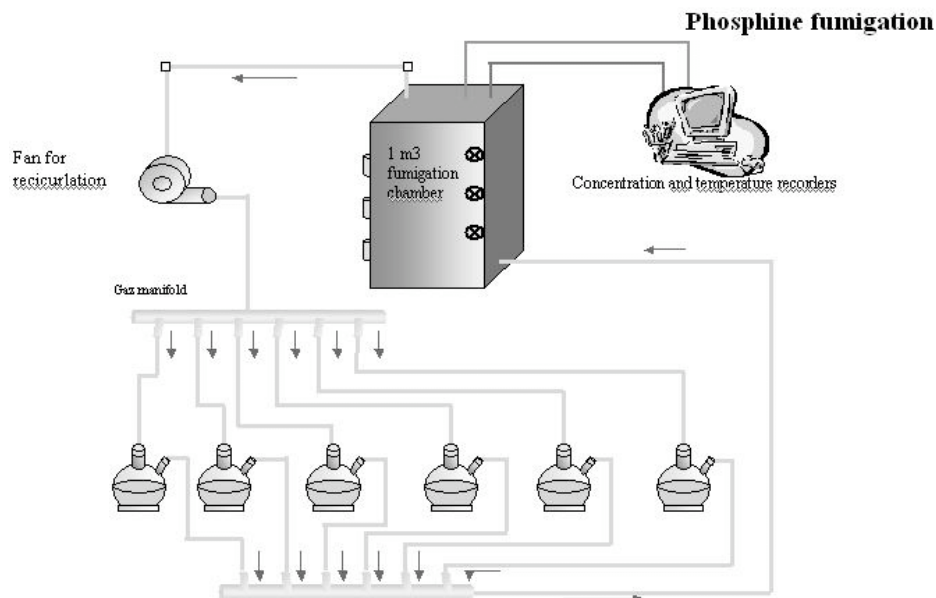

Figure 3. Fumigation system showing fumigation chamber, distribution tubes, fumigation flasks in parallel, recirculation fan and gas monitoring equipment

TABLE 1  
Phosphine efficacy expressed in times in hours, required to produce 99% mortality at 4 temperatures and at 30 ppm and 60 ppm

Temperatures	60 PPM				30 ppm			
	10°C	15°C	20°C	25°C	10°C	15°C	20°C	25°C
Rust-red grain beetle	-(a)	36.5	22.5	11.3	-(a)	6	13	12
Saw-toothed grain beetle	31.6	22.8	12.3	11.7	52	29	20	12
Grain weevil	95	43.6	25/2	19.1	89	88	-(a)	19.1
Rice weevil	37.8	23.2	12.0	-(a)	49	38	15	11-
Maize weevil	58.8	39.2	41.0	22.4	73	60	46	45
Confused flour beetle	34.9	65.5	35.1	27	103	80	64	58
Rust-red flour beetle	55.7	34.3	14.0	13.1	81	41	34	13
Average DL 99 (hours)	52	38	25	18	75	57	37	26

(a) File lost

If there are no highly-resistant strains present (if present, the treatment may fail), then phosphine requires only a few hours to kill the active and visible stages, even at low temperatures and low concentrations. Therefore low concentrations and short fumigations are of great interest since desorption is also very quick under these conditions (Noack *et al*, 1983).

### CONCLUSIONS

The results show that the use of phosphine may help to deliver quickly a clean material for the food industry. It may be compared with a DDVP treatment producing rapid disinfestation without leaving residues.

Although this method may be controversial it should not lead to more resistance since all adult insects will be destroyed by the process. Further work should be done on larvae of both coleoptera and lepidoptera commonly encountered in stored products. To avoid misuse, a clear contract should be established between pest control operator and client to specify the limitations of this disinfestation procedure.

### REFERENCE

- Noack S., Reichmuth C. und Wohlgemuth R., (1983) PH<sub>3</sub> Rückstände bei Vorratsschutzbegasungen in Abhängigkeit von der Konzentration, Einwirkzeit und Lagerdauer nach der Begasung. *Z.Lebensmittel-Untersuchung und-Forschung*, **177**, pp:87-93.